

6019i Schematics

Baseband - Top

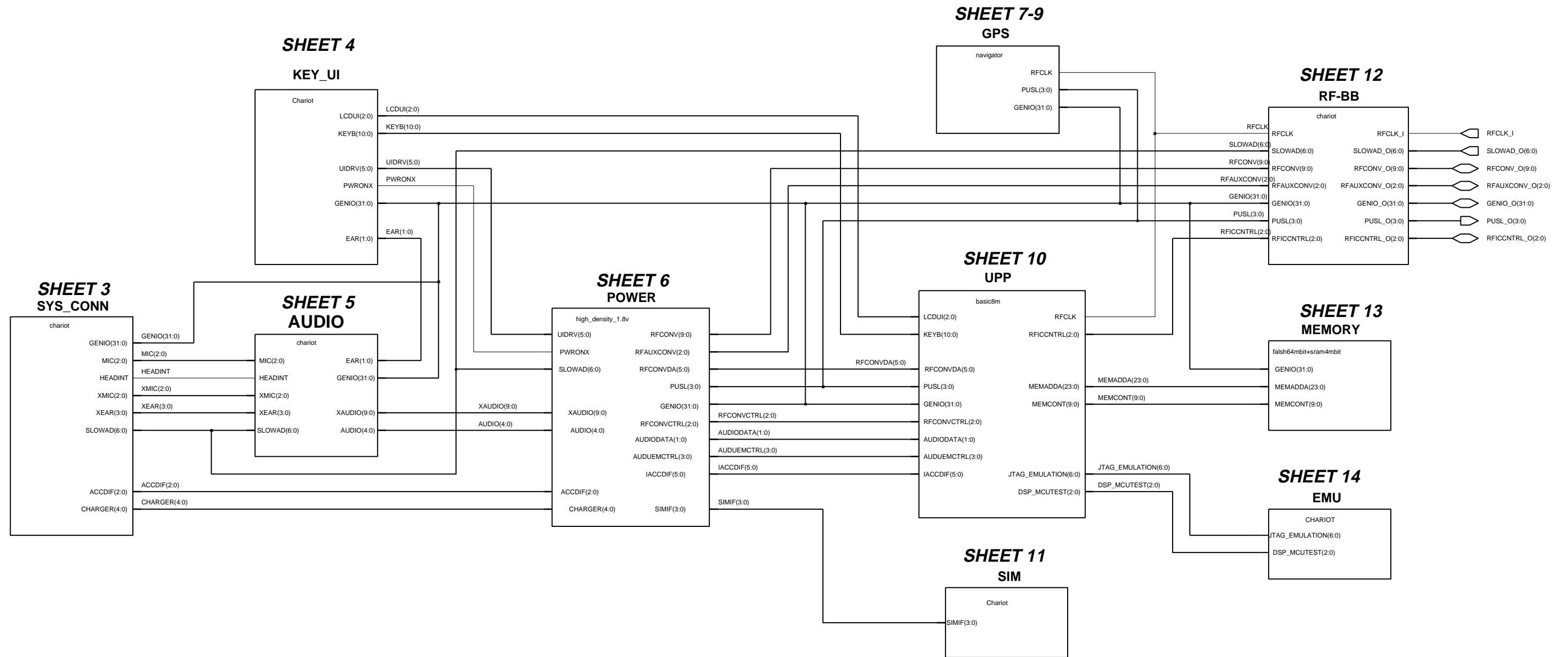

Front End

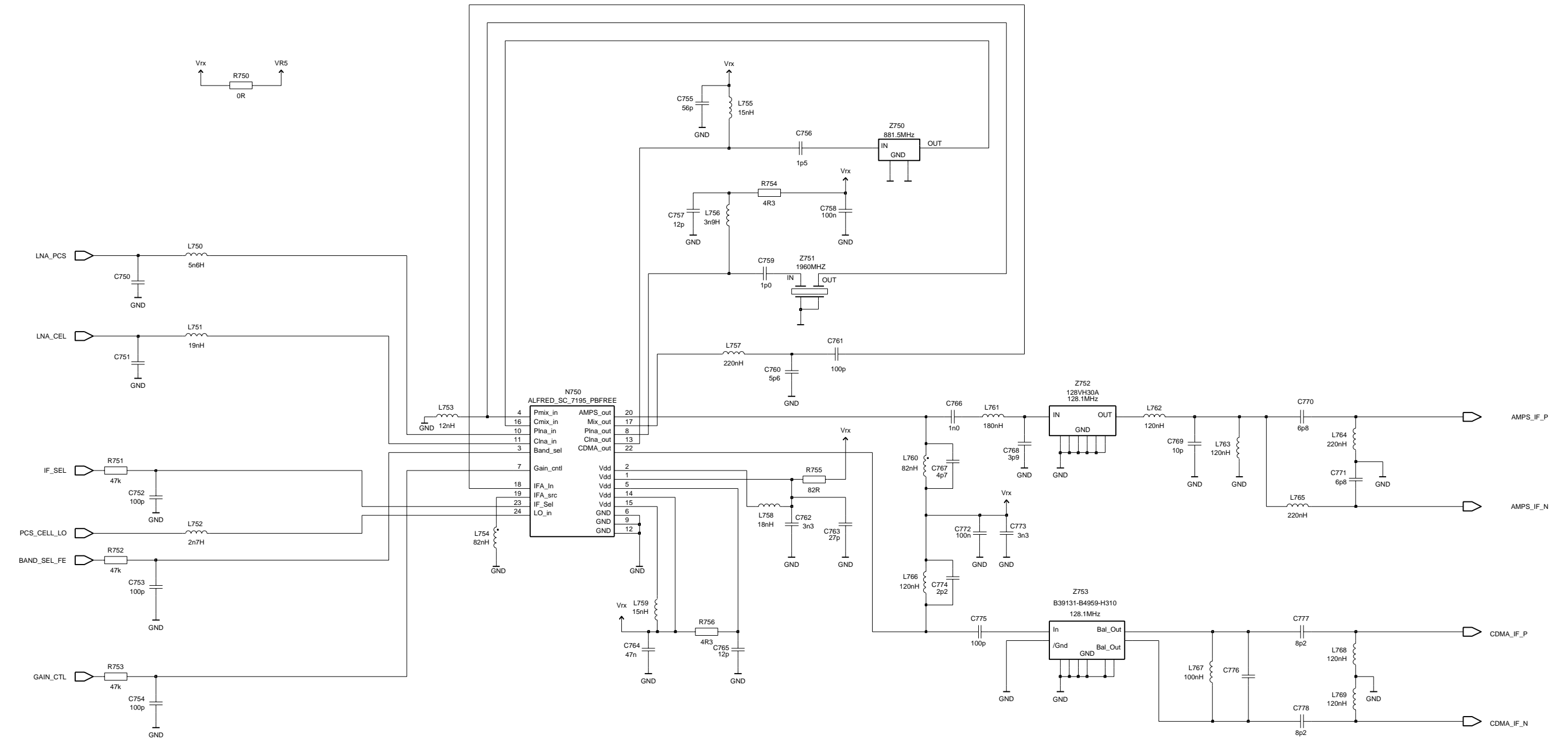

MODES	LOGIC INPUTS		
	BAND	GAIN_CTL	IF_SEL
CEL CDMA Hi Gain	0	1	0
CEL CDMA Lo Gain	0	0	0
PCS CDMA Hi Gain	1	1	0
PCS CDMA Lo Gain	1	0	0
AMPS Hi Gain	0	1	1
AMPS Lo Gain	0	0	1

VARIANT DNI	
HDB91 800	HDC93 1900
C750	C751
C759	C756
L750	C766
Z751	C768
	C769
	C770
	C771
	L751
	L761
	L762
	L763
	L764
	L765
	Z750
	Z752

Audio

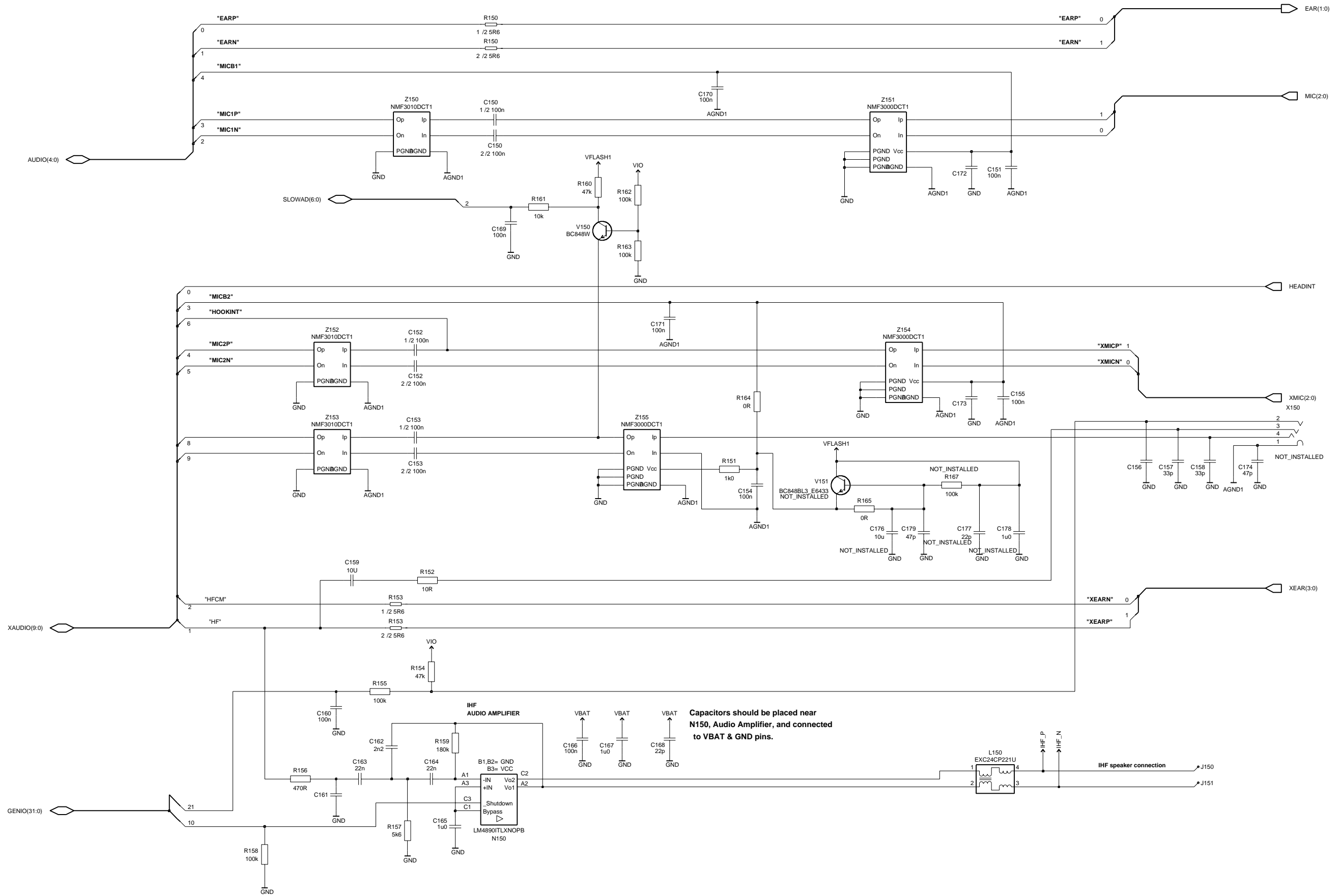

GPS Baseband

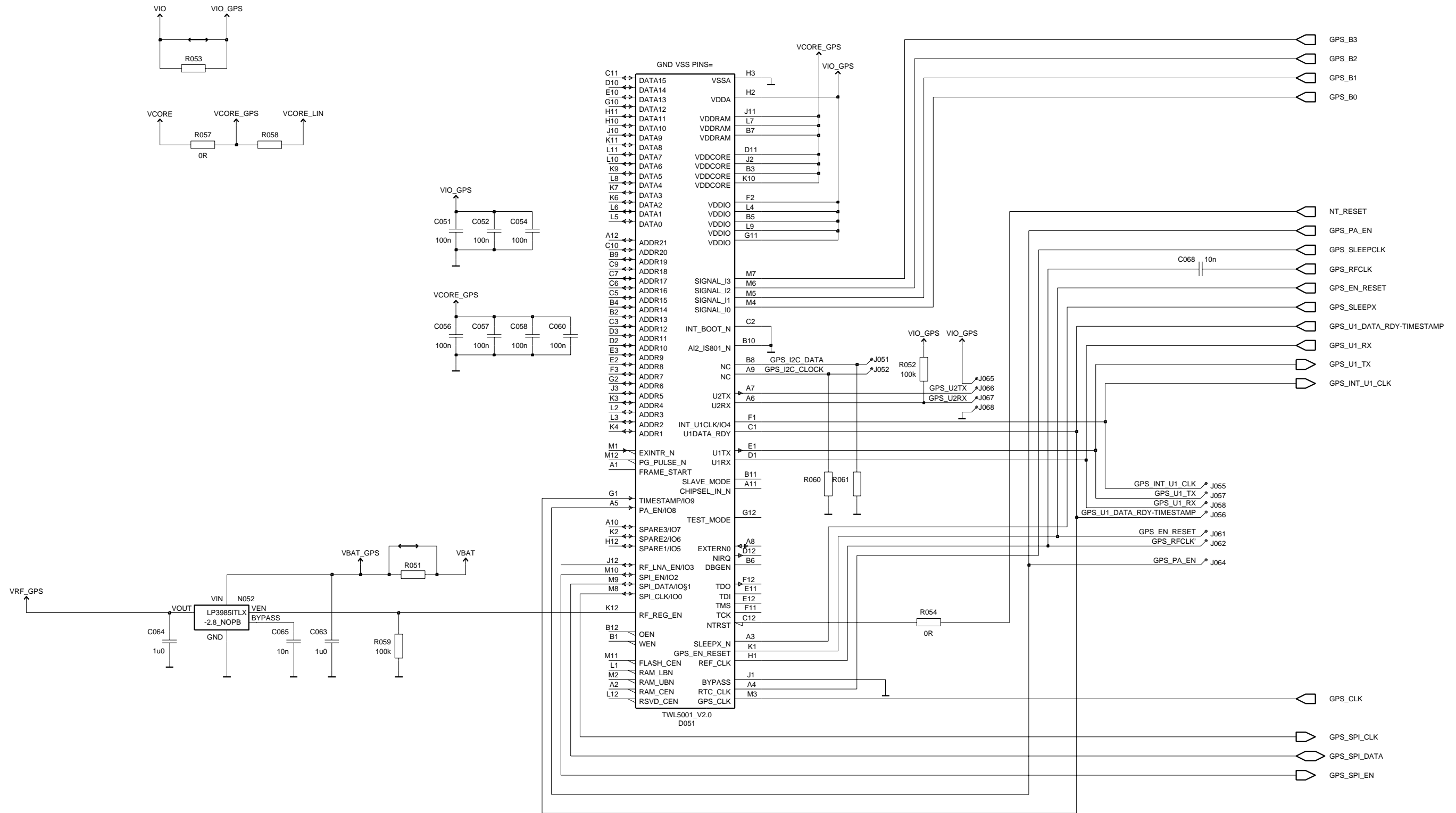

GPS RF

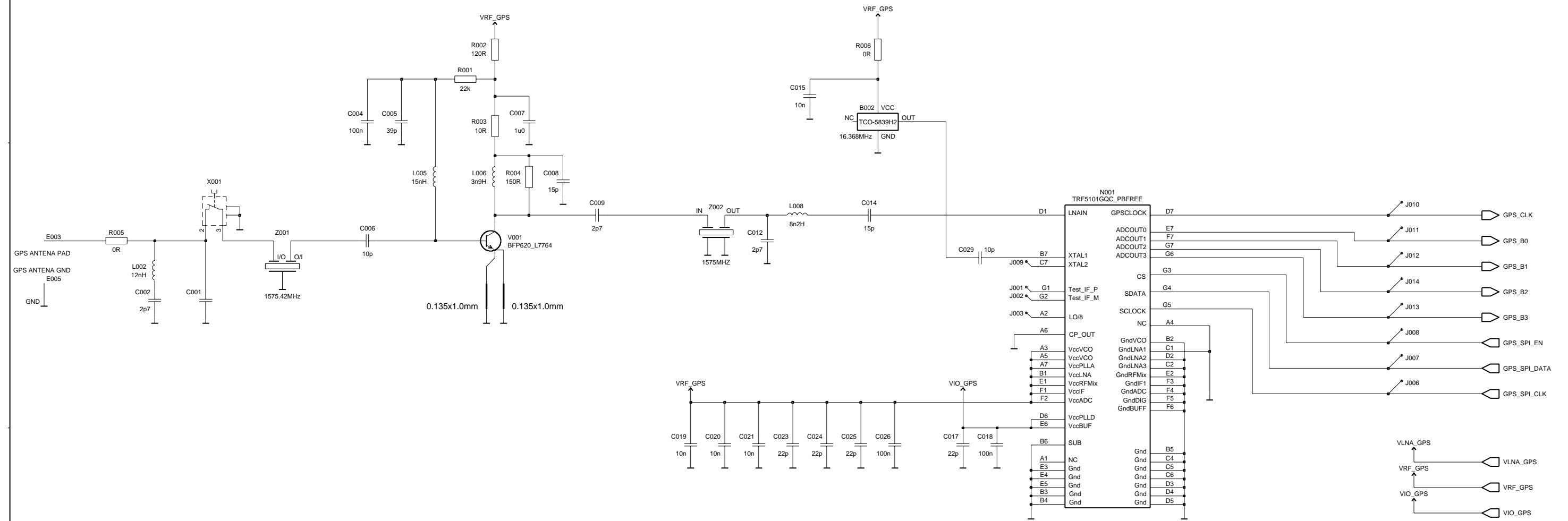

GPS RF BB Interface

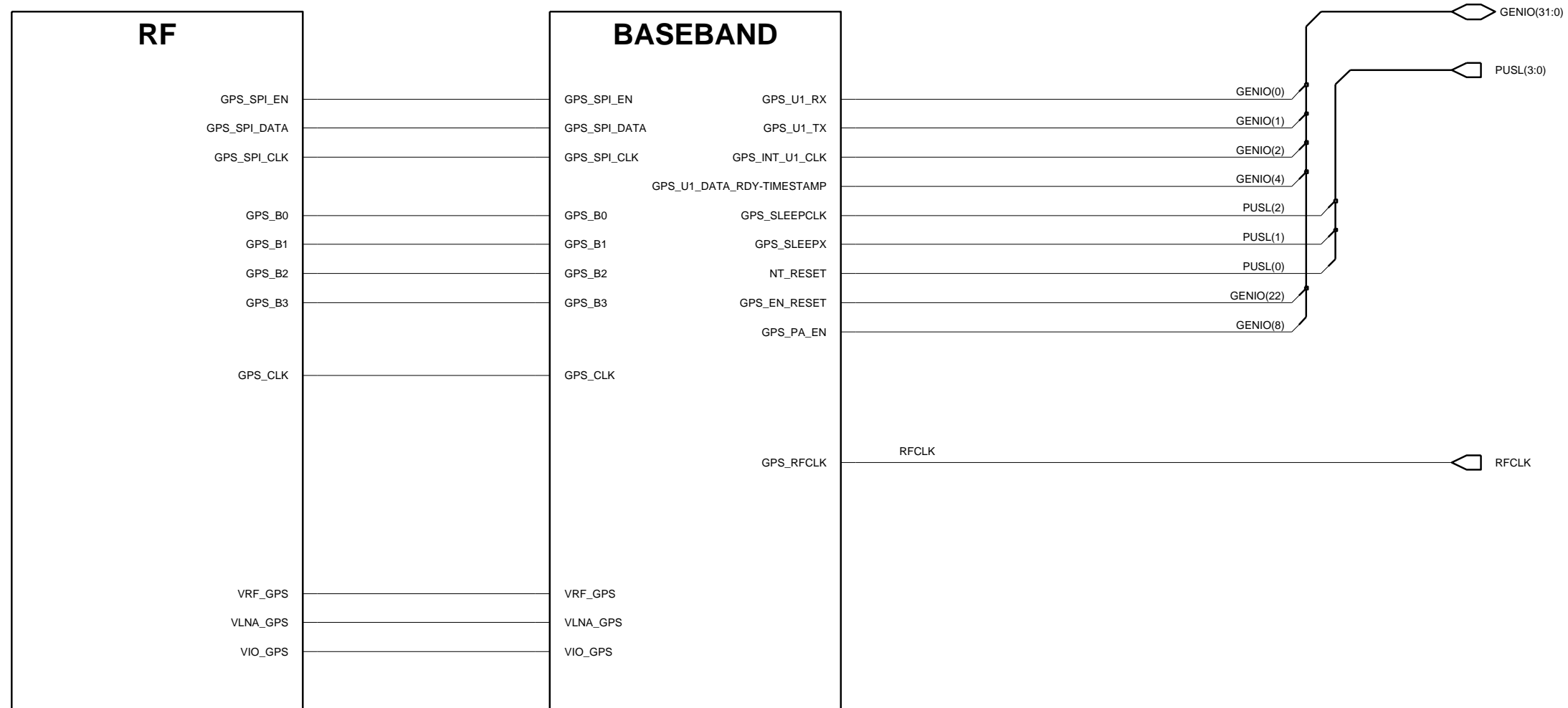

Batman

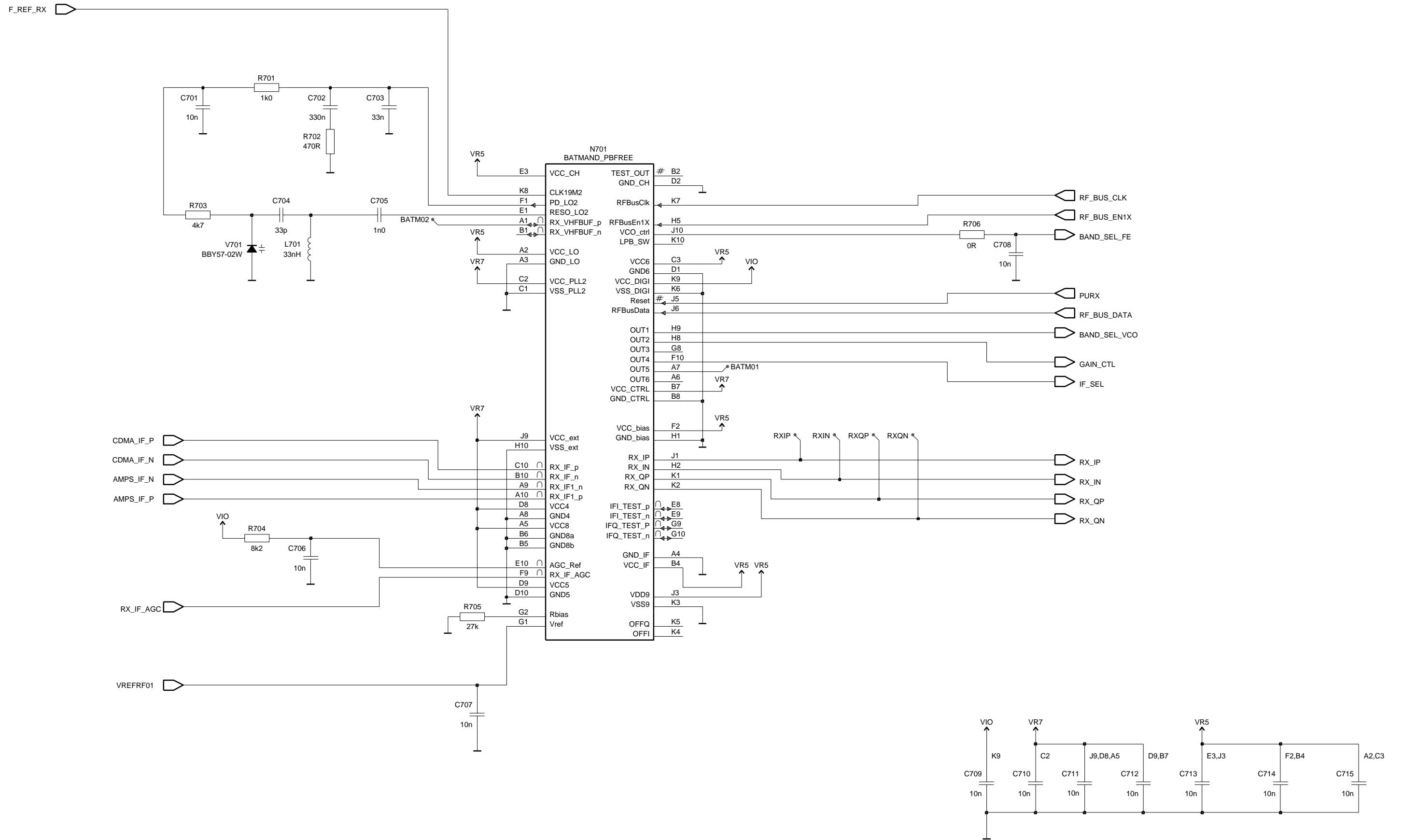

Key UI

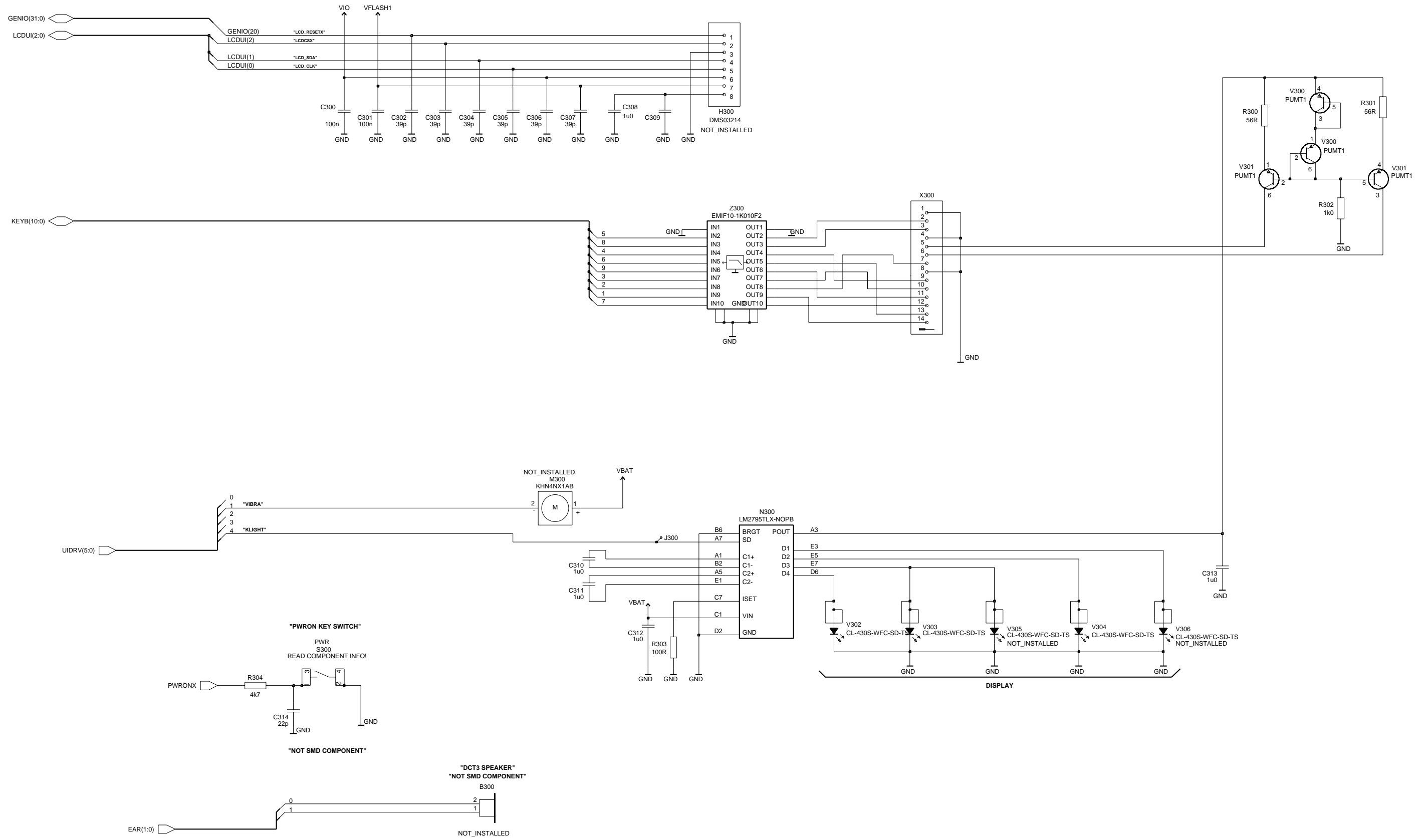

Memory

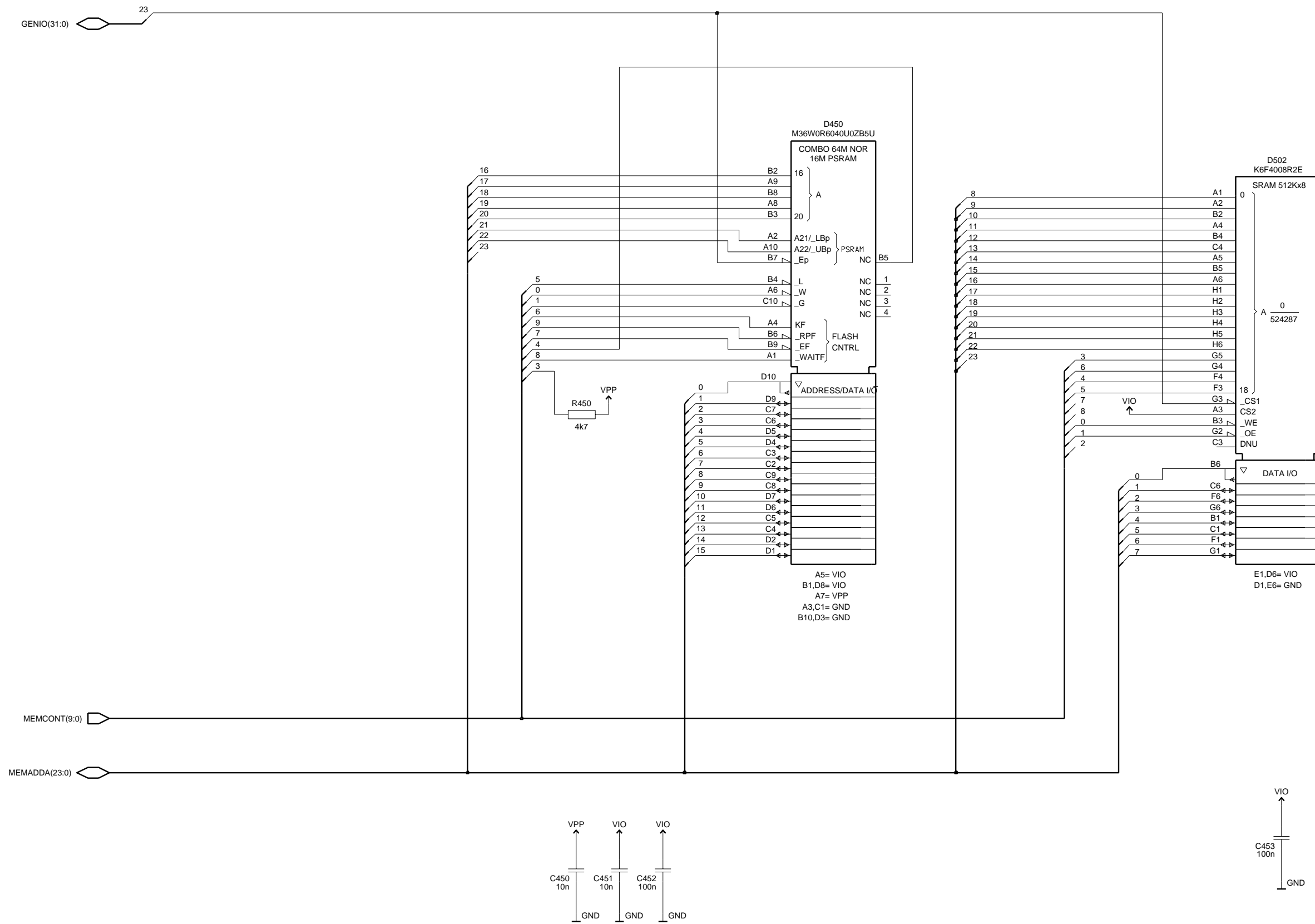

PA

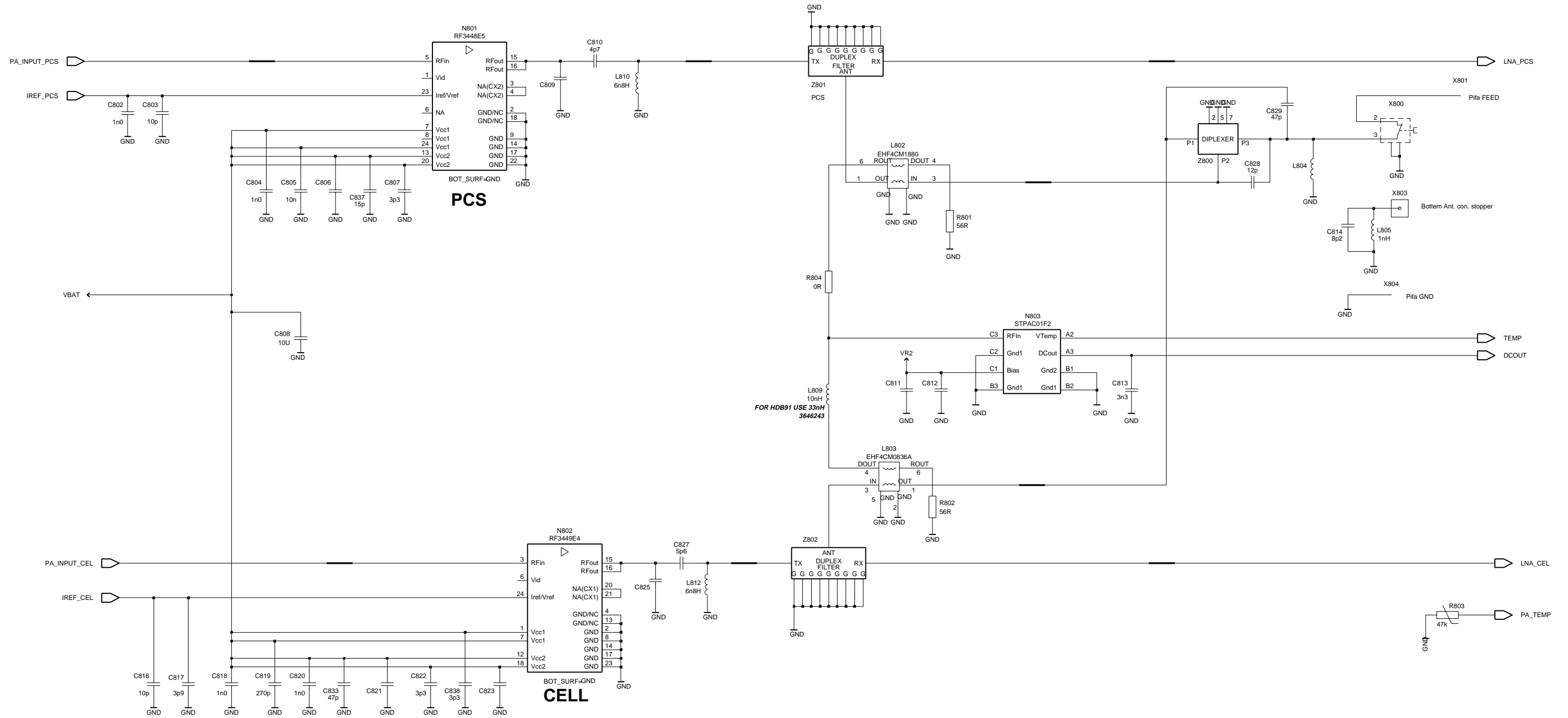

VARIANT DNI		
HDC91 DB	HDB91 800	HDC93 1900
C828	C802	C816
C829	C803	C817
	C804	C818
	C805	C819
	C806	C820
	C807	C821
	C809	C822
	C810	C823
	C828	C825
	C837	C827
	L802	C829
	L810	C833
	N801	C838
	R801	L803
	R804	L808
	Z800	L811
	Z801	R802
		Z800
		Z802

RF-BB Interface

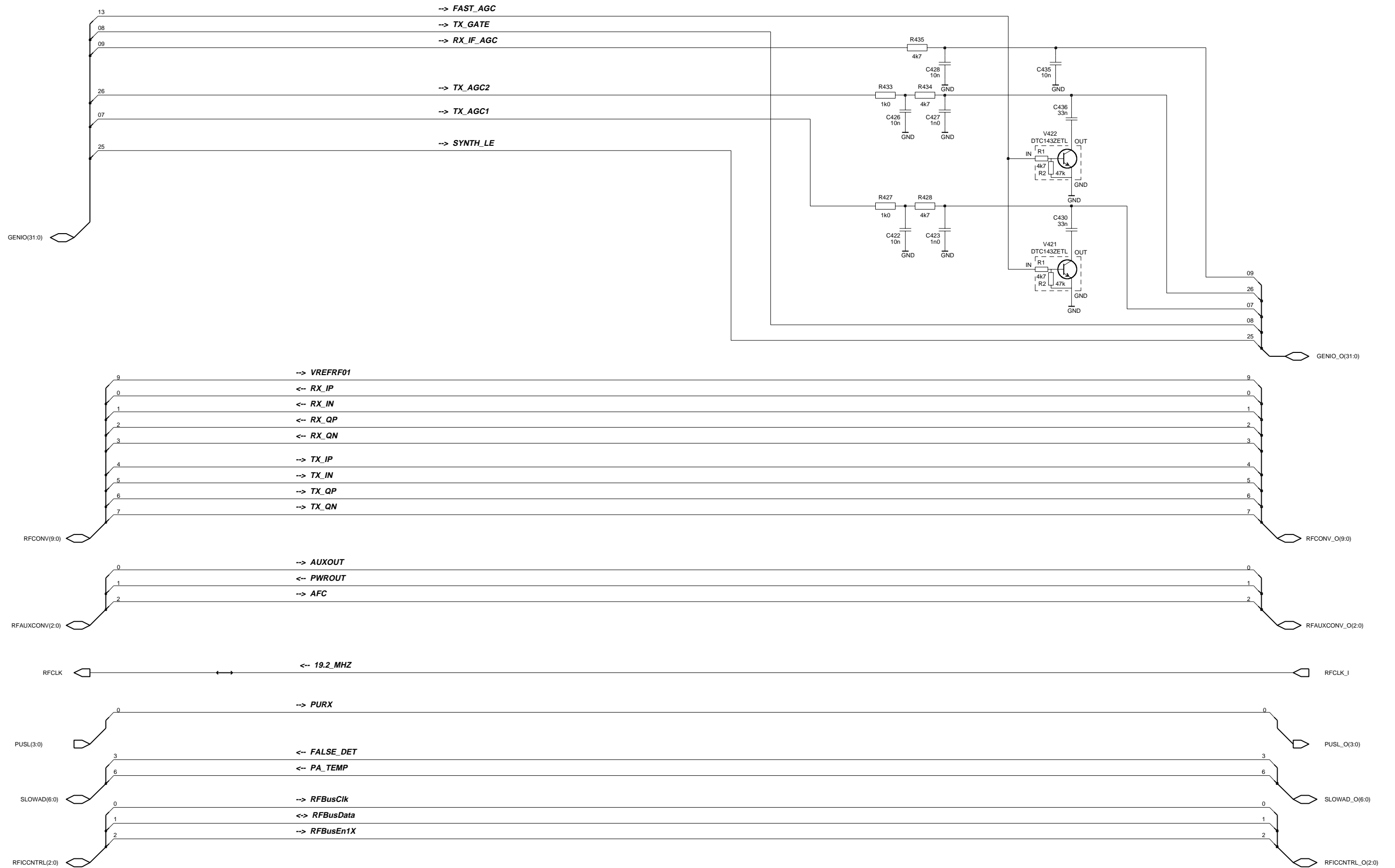

RF - Top

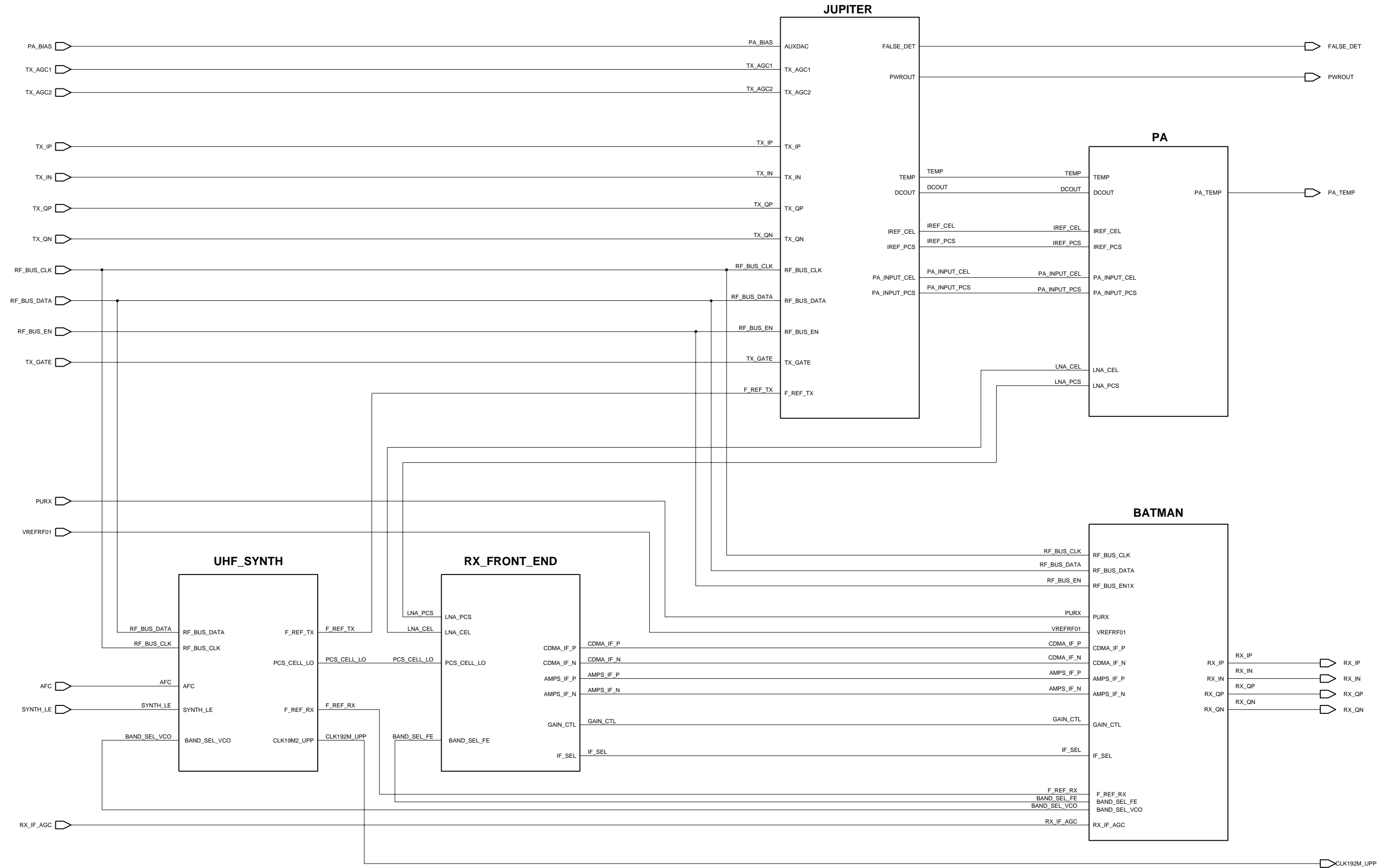

SIM

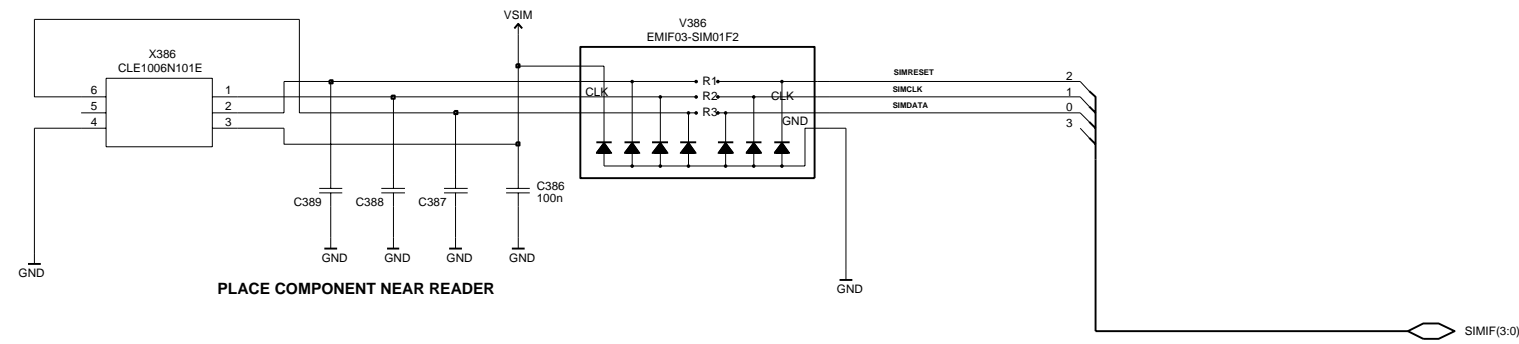

Test and Emulator Interface

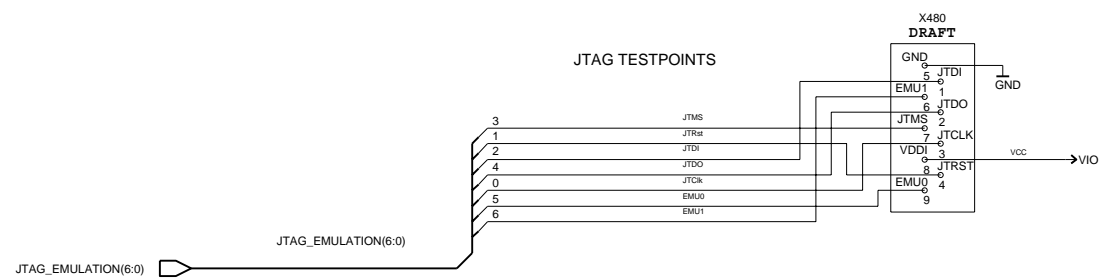

System Connector

TEST POINTS FOR BATTERY

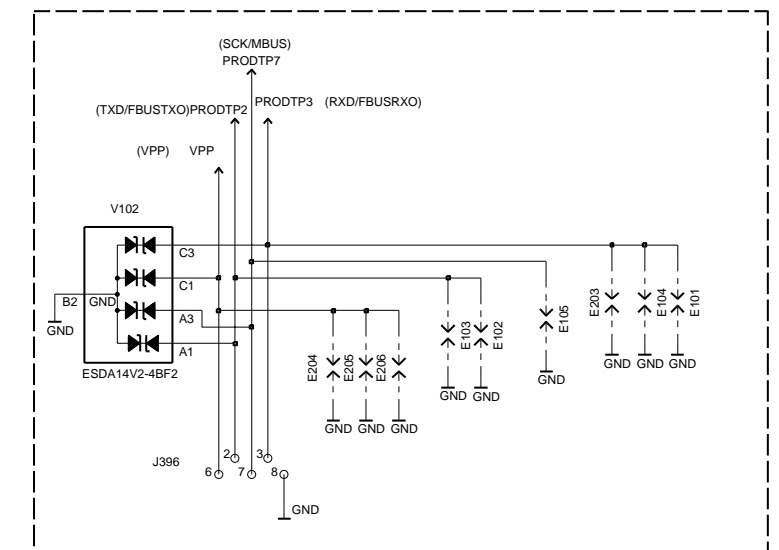
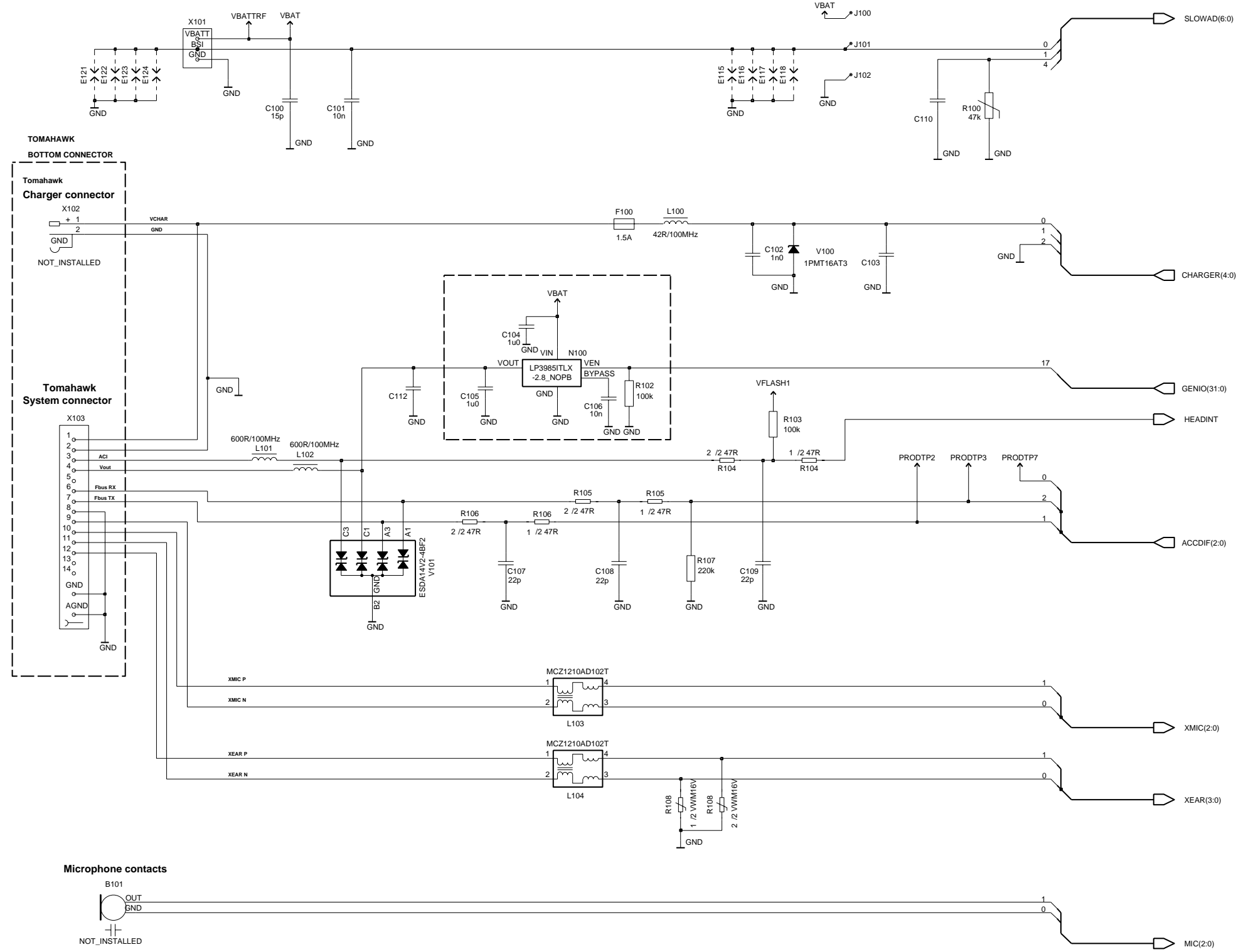

PROD TEST PATTERN

UHF Synthesizer

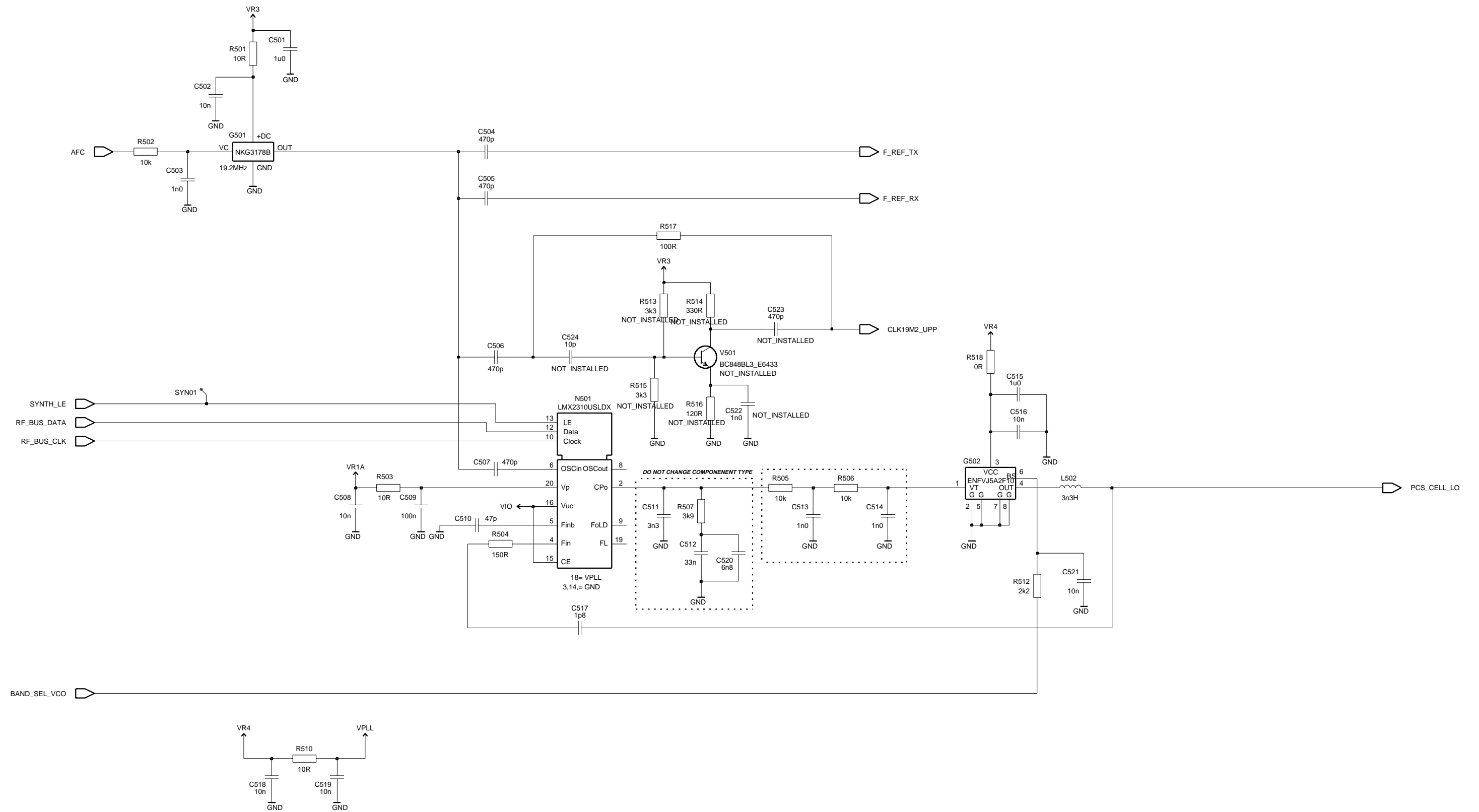

Top Level

RF

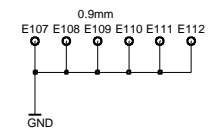
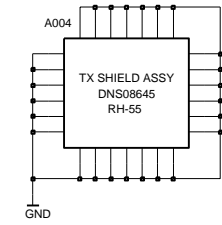
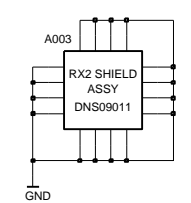
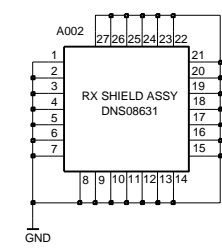
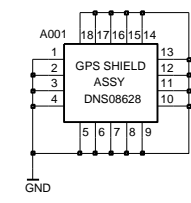
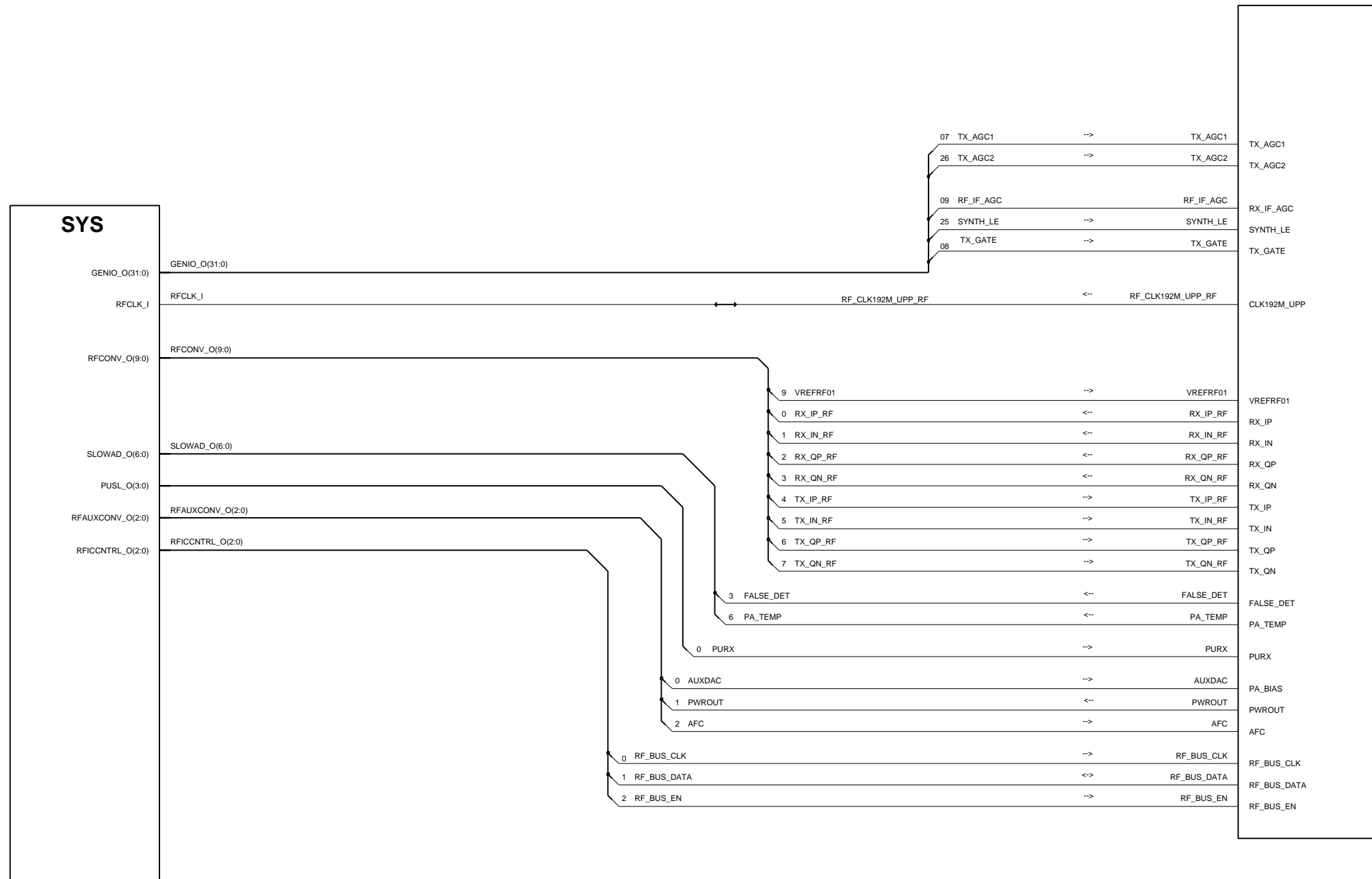

Mechanical Plated Thru Holes

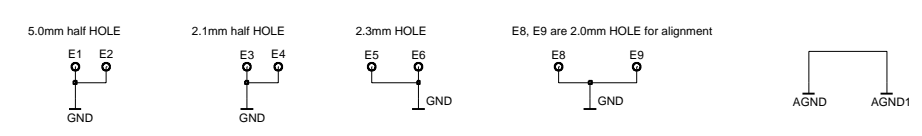

UEM

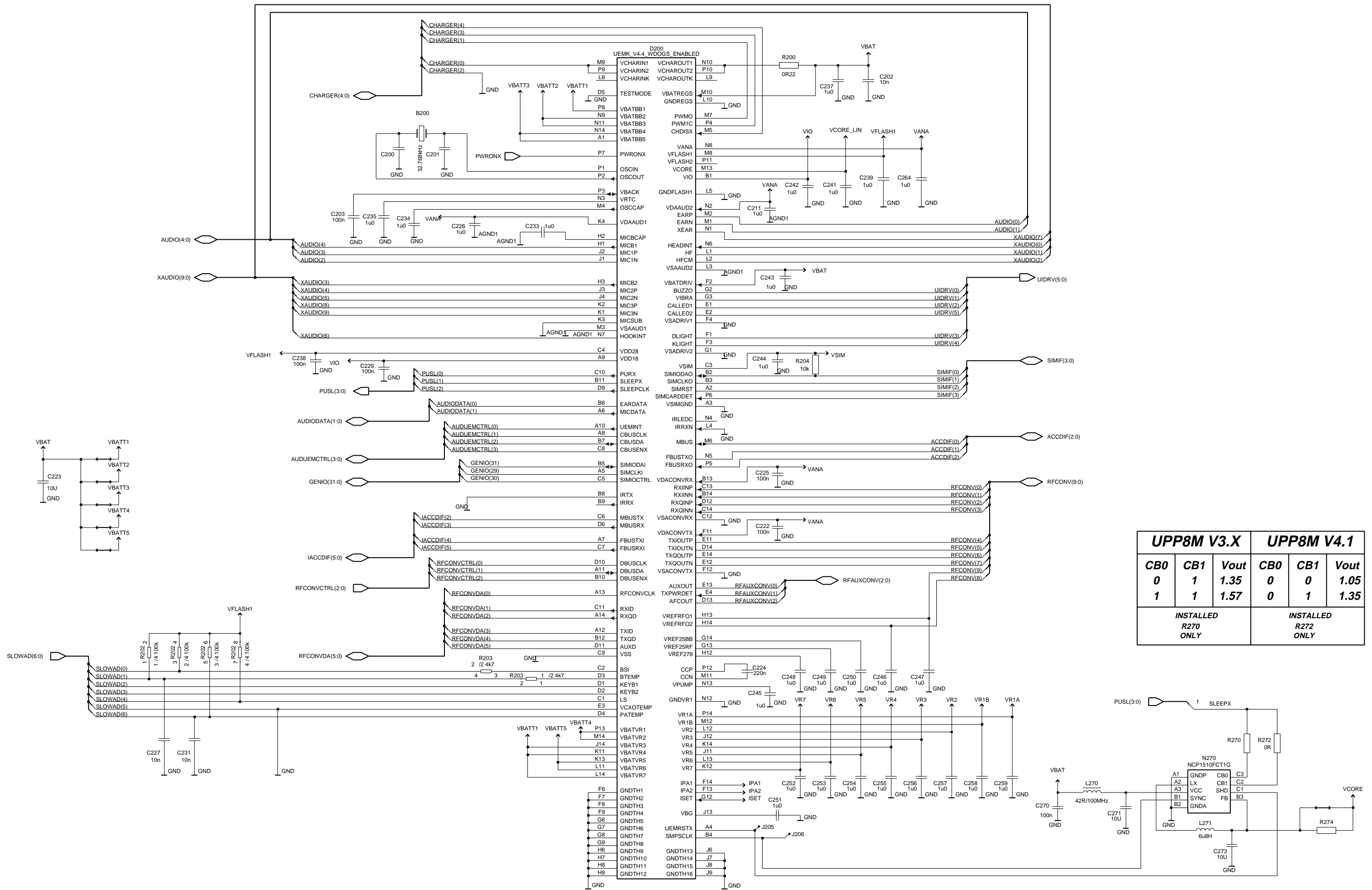

UPP8M V3.X			UPP8M V4.1		
CB0	CB1	Vout	CB0	CB1	Vout
0	1	1.35	0	0	1.05
1	1	1.57	0	1	1.35
INSTALLED R270 ONLY			INSTALLED R272 ONLY		

UPP

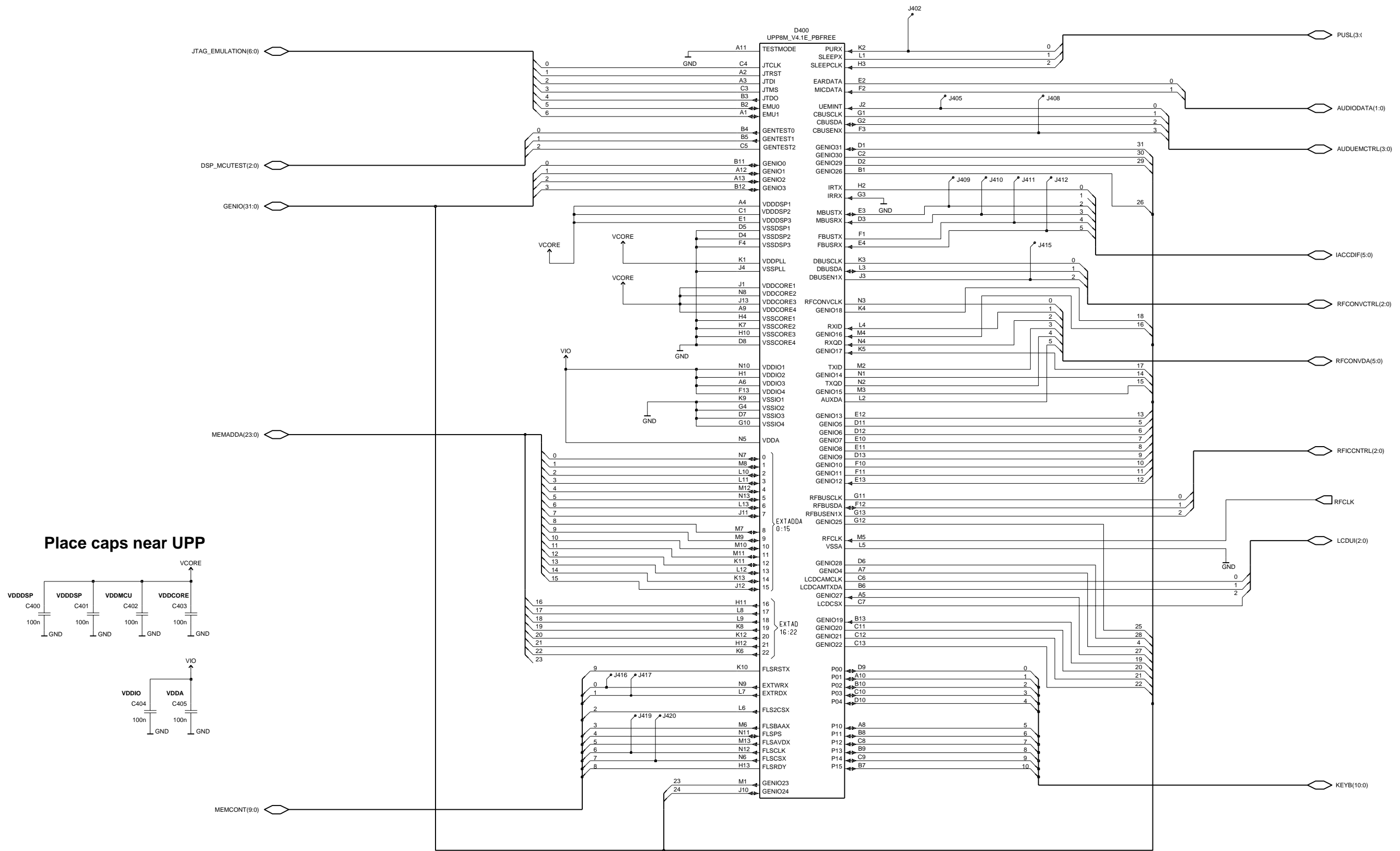

Place caps near UPP

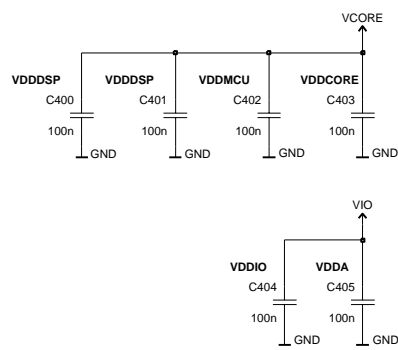

Jupiter

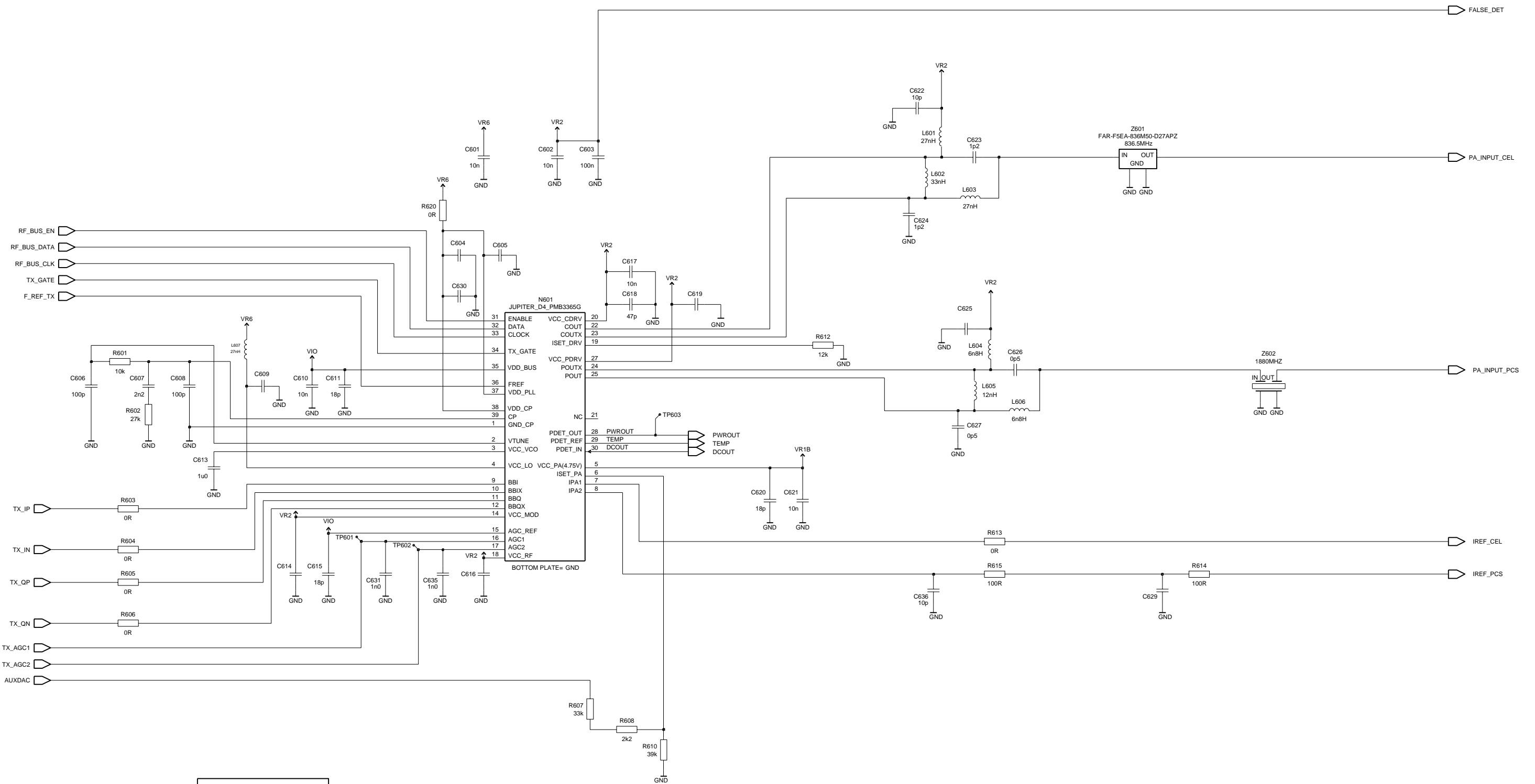

VARIANT DNI	
HDB91 800	HDC93 1900
C625	C622
C626	C623
C627	C624
C629	L601
L604	L602
L605	L603
L606	R613
R614	Z601
Z602	

6019i — 0202499 Component Layout — Top

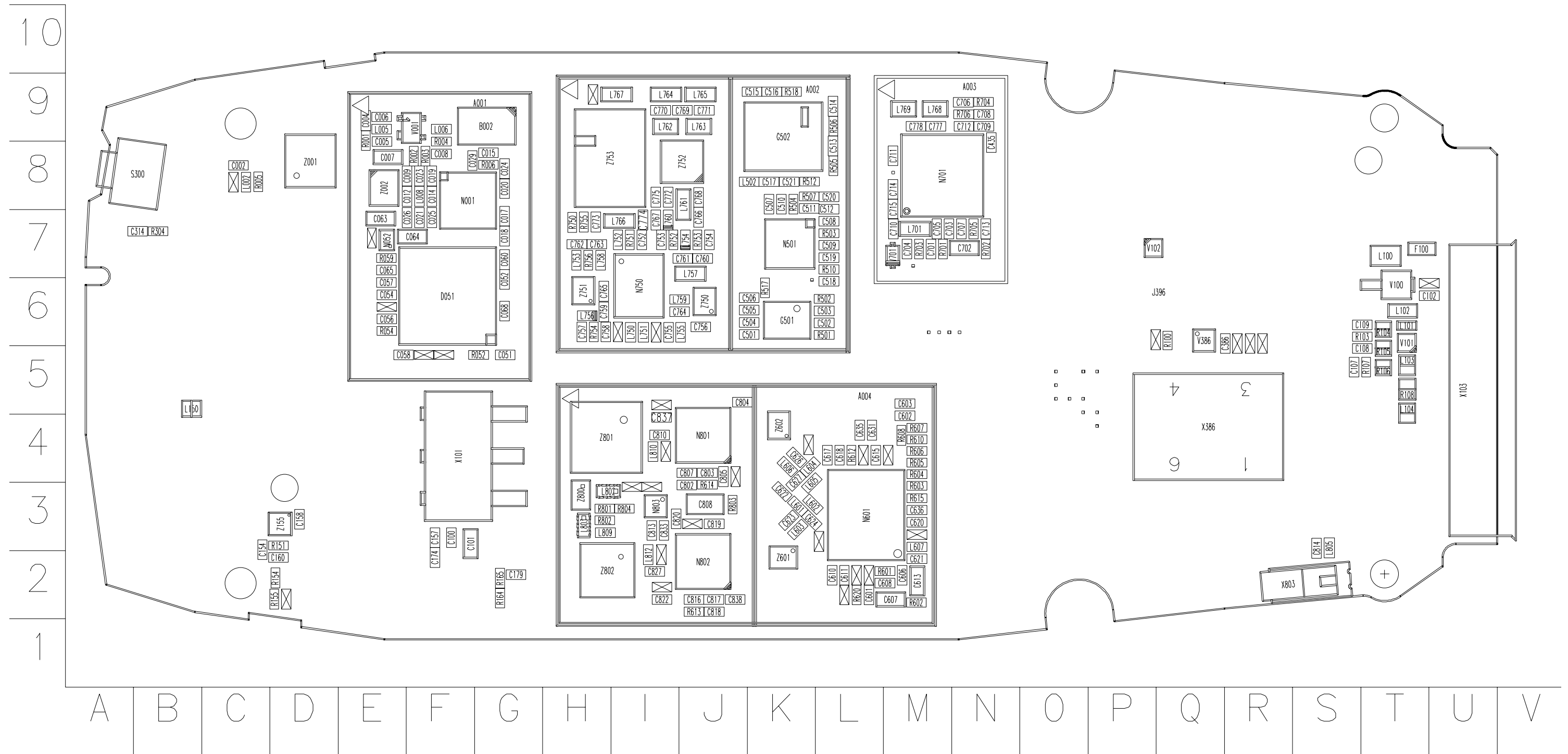

6019i — 0202499 Component Layout — Bottom

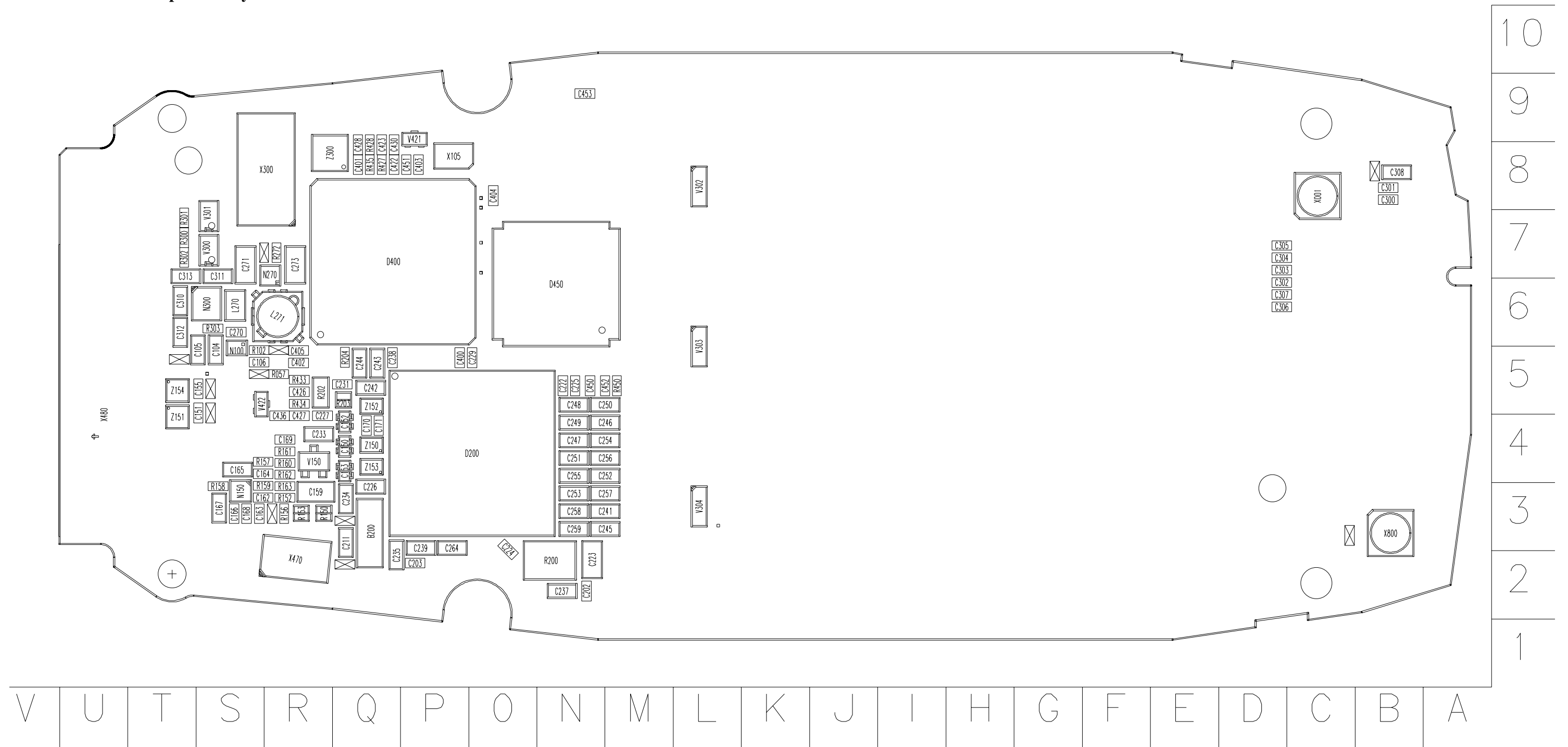

6019i — 0202499 Component Values — Bottom

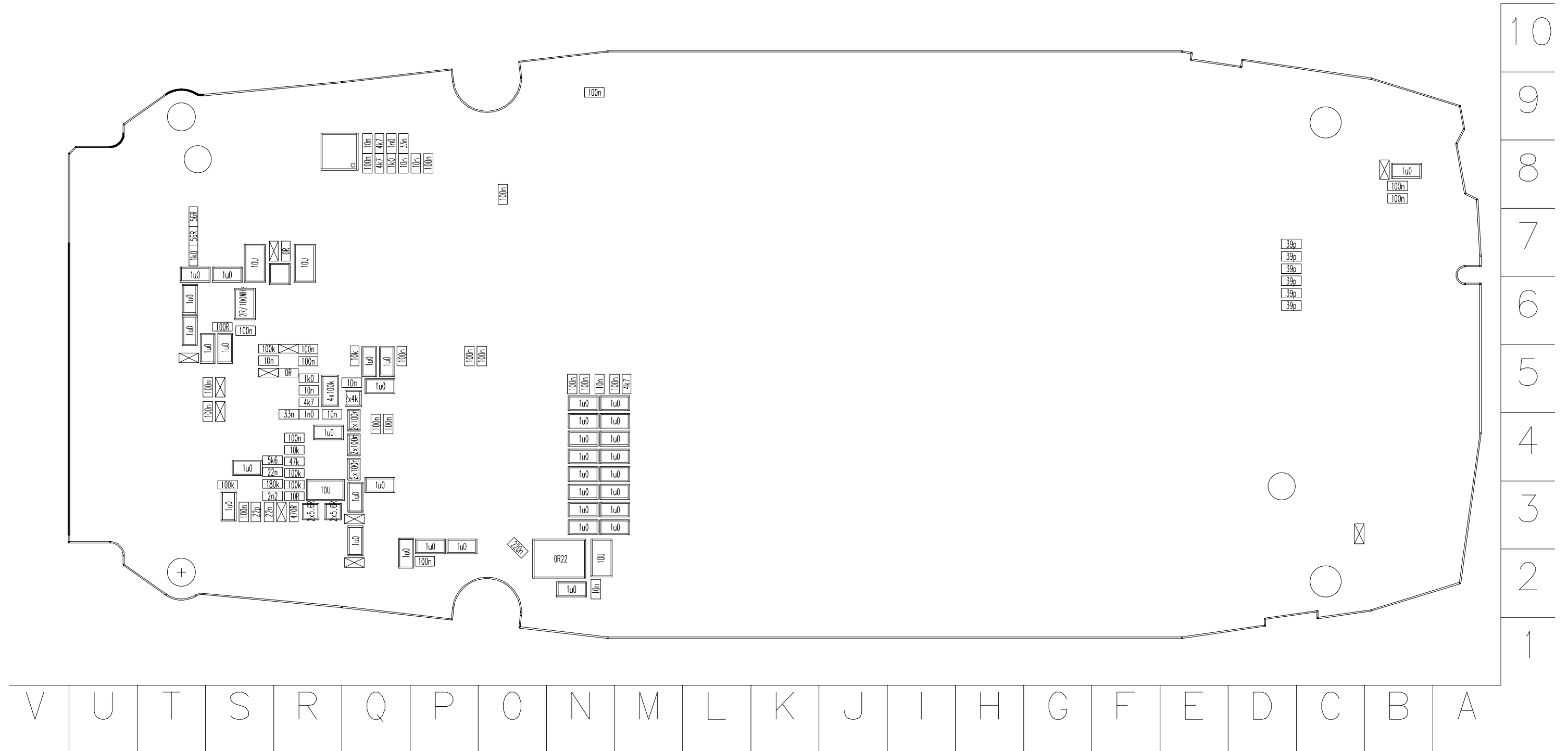

6019i — 0202500 Component Layout — Top

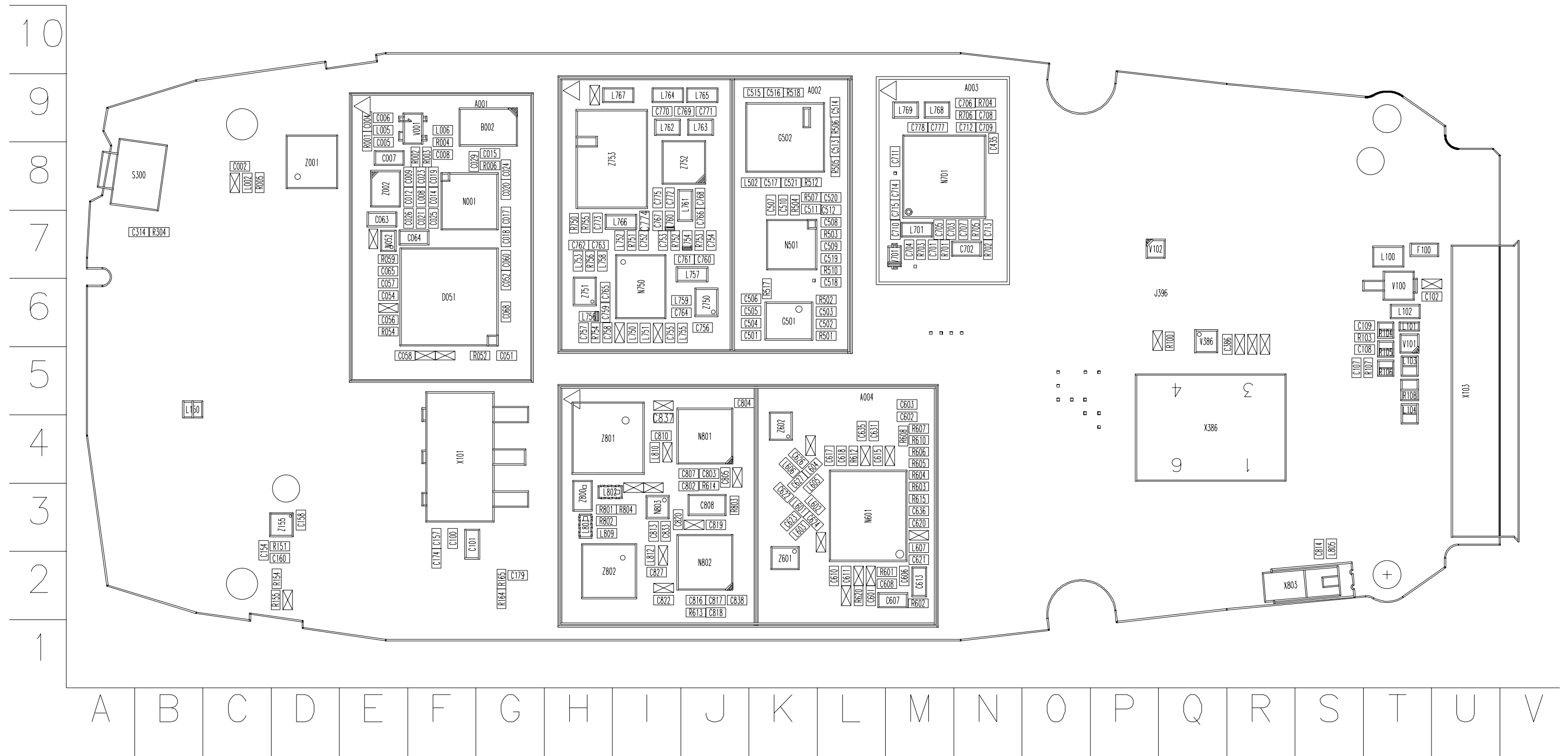

6019i — 0202500 Component Layout — Bottom

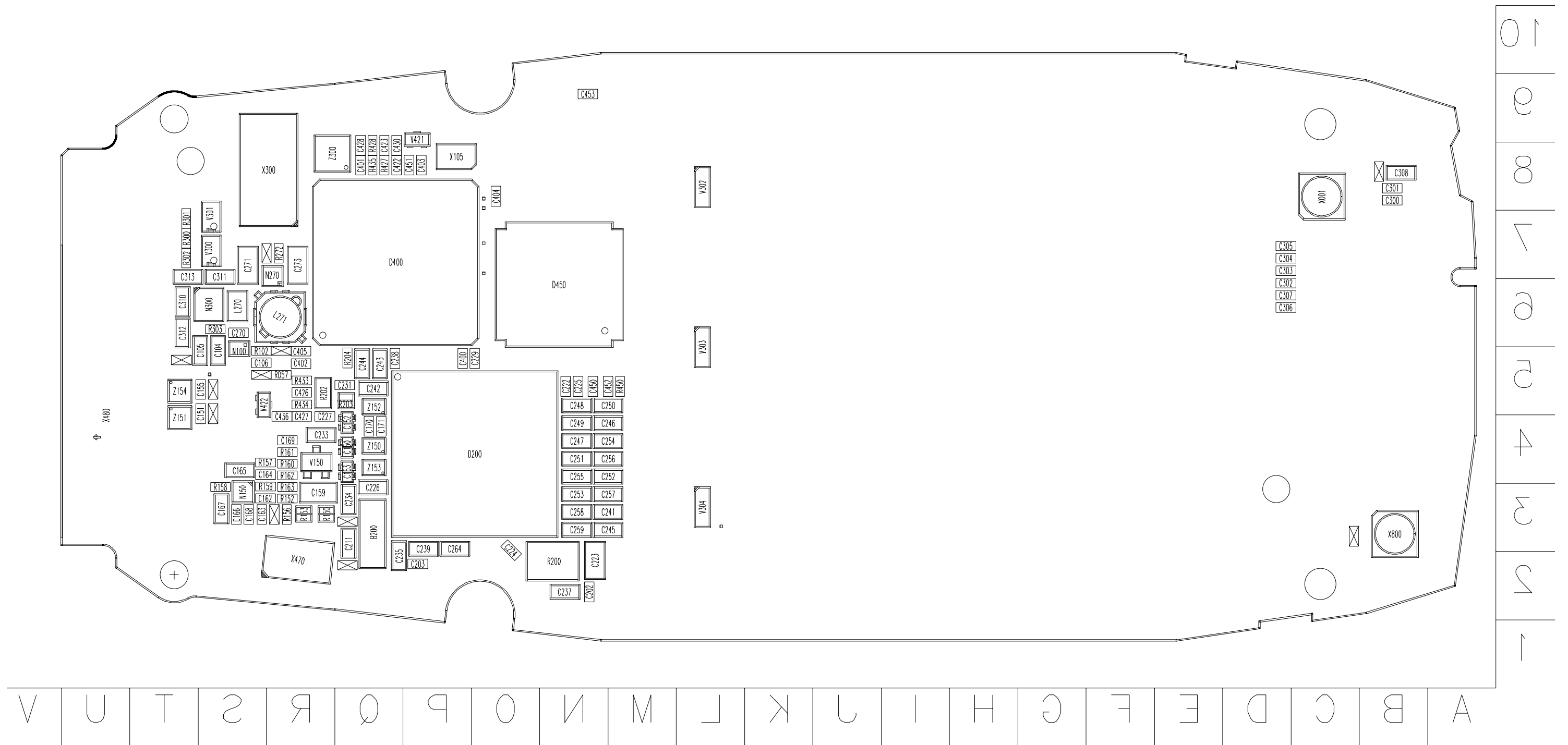

This page intentionally left blank.